

INSTRUCTIONS

REHAU PD1 AND PD2 THERMOSTAT

Table of Contents

Specifications	1
Display / Keypad Operation	2
General.....	2
Sequence of Operation.....	4
Installation.....	6
View Menu	8
Adjust Menu.....	9
Error Messages.....	15
Wiring Examples.....	17

Specifications

Programmable Thermostat PD1 One Stage Heat Art. 236457

Control — Microprocessor PI control; This is not a safety (limit) control.
Packaged weight — 0.46 lb. (210 g), Enclosure J, white PVC plastic.
Dimensions — 2-7/8" H x 2-7/8" W x 13/16" D (73 x 73 x 21 mm)
Approvals — CSA C US, meets ICES & FCC regulations for EMI/RFI.
Ambient conditions — Indoor use only, 32 to 122°F (0 to 50°C), < 90% RH non-condensing.

Power supply — 24 V \pm 10% 60 Hz 3 VA
Relays — 24 V (ac) 2 A, Latching
Sensors — NTC thermistor, 10 k Ω @ 77°F (25°C \pm 0.2°C) β =3892
Optional — REHAU #: 070, 071, 072, 073, 079.

Programmable Thermostat PD2 Two Stage Heat / Heat-Cool Art. 236467

Control — Microprocessor PI control; This is not a safety (limit) control.
Packaged weight — 0.46 lb. (210 g), Enclosure J, white PVC plastic
Dimensions — 2-7/8" H x 2-7/8" W x 13/16" D (73 x 73 x 21 mm)
Approvals — CSA C US, meets ICES & FCC regulations for EMI/RFI.

Ambient conditions — Indoor use only, 32 to 122°F (0 to 50°C), < 90% RH non-condensing.

Power supply — 24 V \pm 10% 60 Hz 3 VA
Relays — 24 V (ac) 2 A, Latching
Sensors — NTC thermistor, 10 k Ω @ 77°F (25°C \pm 0.2°C) β =3892
Included — None
Optional — REHAU type #: 070, 071, 072, 073, 079.

The information contained herein is believed to be reliable, but no representations, guarantees, or warranties of any kind are made as to its accuracy, suitability for particular applications or the results to be attained therefrom. Before using, the user shall determine suitability of the information for user's intended use and shall assume all risk and liability in connection therewith. To the extent permitted by law, REHAU DISCLAIMS ALL WARRANTIES, EXPRESS OR IMPLIED, INCLUDING BUT NOT LIMITED TO ANY IMPLIED WARRANTIES OF MERCHANTABILITY OR OF FITNESS FOR A PARTICULAR PURPOSE.

Display / Keypad Operation

The thermostat's display has four distinct fields. These fields are the Menu field, the Item field, the Number field and the Status field. The four buttons on the face of the thermostat are used to navigate through the menus and items to view and / or adjust the desired settings.

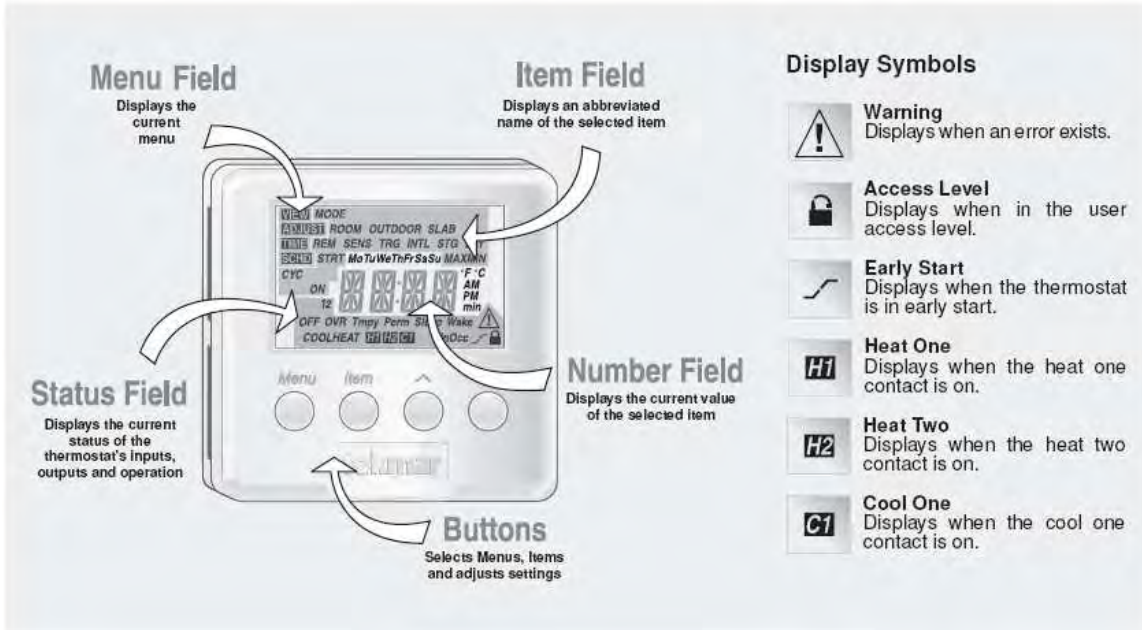

General

These thermostats have electronic circuitry that not only is "reading" the room temperature and / or the external sensor (typically a floor sensor) but also is monitoring the heating cycles and accumulating a "knowledge" of just how the heating system is working. This allows the thermostat to "anticipate" the system and prevent a system "short cycling".

In order to prevent short cycling of the heating relay(s), the thermostat ensures that the relay(s) remains on or off for a minimum amount of time. In order to prevent short cycling of the Cool relay, the minimum cooling on time and minimum cooling off time settings are adjusted in the Adjust menu of the PD2.

An Auto Cycle setting is available for both the heating cycle and the cooling cycle. This setting allows the thermostat to determine the best number of cycles per hour that balances both temperature swings and equipment cycles.

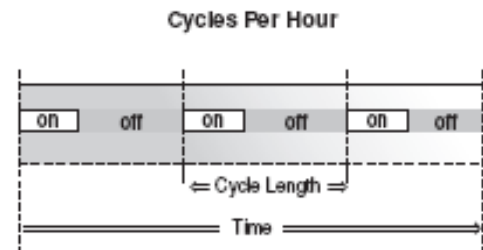

EARLY START

Heating - The early start function for heating ensures that the zone is up to the proper temperature at the beginning of each period. The thermostat learns the recovery rate over multiple setback events in order to determine the proper lead-time for the zone. If both an air sensor and a slab sensor are used, the lead-time is the greater of the air sensors or the slab sensor's requirements.

Cooling - The early start function, when used with cooling, allows the cooling system to turn on 30 minutes prior to the beginning of a period that requires cooling.

Note: The Early Start feature occurs when the schedule changes from a low temperature to a higher temperature.

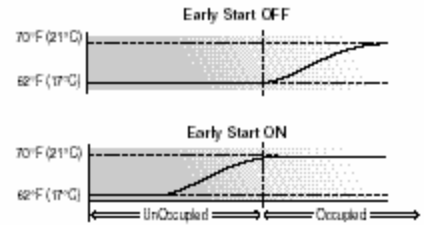

AUXILIARY SENSORS

The thermostat has a single built-in sensor to measure air temperature at the thermostat. In addition to the built-in sensor, the thermostat has terminals to connect one separate sensor. This sensor can be either indoor sensors, slab sensors, a remote sensor, or an outdoor sensor.

Indoor Sensor

An indoor sensor is used to measure the air temperature in the zone that the thermostat is controlling. The temperature being read by the indoor sensor is used in the calculations of the on times for the relay(s) in the thermostat. If more than one sensor, either the built-in sensor or an auxiliary sensor set as an indoor sensor, is being used to measure the zone temperature, the temperature of the active sensors is averaged and used to calculate the on time of the relay(s).

Slab Sensor

A slab sensor is used to measure the slab temperature in the zone that the thermostat is controlling. The temperature being read by the slab sensor is used in the calculations of the on time for the Heat relay and allows the thermostat to operate the slab between the slab minimum and slab maximum settings. If more than one slab sensor is used, the slab temperatures are averaged by the thermostat.

Remote Sensor

A single remote sensor can be connected to the thermostat. The temperature measured by a remote sensor does not affect the on time of the relays and is only used for display purposes.

Outdoor Sensor

A single outdoor sensor can be connected to the thermostat. The temperature measured by an outdoor sensor does not affect the on time of the relays and is only used for display purposes.

ACCESS LEVELS

The REHAU Programmable Thermostat has two access levels. These access levels restrict the number of items available in the menus of the thermostat. The two access levels are Installer and User. This selection is made using the DIP switch located on the circuit board inside the thermostat.

- 1-OFF
- 2-OFF

The Installer access level allows the installer to adjust all of the setting in the thermostat including those required to match the thermostat to the mechanical system and the devices used. A "lock" icon is displayed in lower right.

- 1-ON
- 2-ON

The User access level allows the end user to adjust the time, temperatures and schedules used by the thermostat. A "lock" icon is displayed in lower right while in the MENU mode.

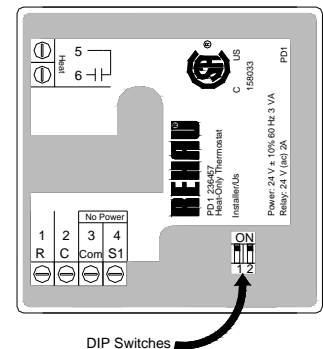

Sequence of Operation

PD1 (One Stage Heat)

Air Sensor(s) Only Operation

When operating with only an air sensor, the on time for the Heat relay is calculated to satisfy the requirements of the air sensor.

Slab Sensor Only Operation

When operating with only a slab sensor, the on time for the Heat relay is calculated to satisfy the requirements of the slab sensor. The thermostat operates to maintain the slab at the minimum slab temperature setting.

Note: Operating with only a slab sensor can lead to either overheating or under heating of the space.

Air and Slab Sensor Operation

When operating with both air and slab sensors, the thermostat calculates an on time for the Heat relay to satisfy the slab sensor's requirements and an on time to satisfy the air sensor's requirements. The Heat relay operates for the longer of these two on times. During light heating loads, overheating can occur due to the minimum slab temperature requirements. During heavy heating loads, the maximum slab temperature setting limits the on time of the Heat relay. In this situation, underheating can occur.

Mode

Heat In the heat mode, the Heat relay is operated to satisfy the temperature requirement of the zone.

Off In the Off mode, the Heat relay is not operated.

Note: If an air or slab sensor is active in the Off mode, a freeze protection is enabled that allows the Heat relay to be operated to keep the zone above 35°F (2 °C).

PD2 (Two Stage Heat)

The two stage mode of operation is selected using the DIP switch located on the circuit board inside the thermostat.

In cases where a one stage heating system can not provide sufficient heat under all conditions, a second stage of heat can be added to supplement the first stage. A two stage system therefore has one thermostat controlling two output relays.

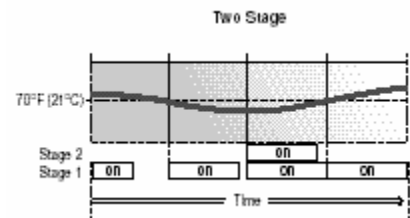

Two Stage Logic

The temperature in a two stage zone is controlled by varying the on time of the Heat 1 and Heat 2 relays during a cycle. Under light loads, the Heat 1 relay is cycled on and off. As the load increases, the Heat 1 relay on time is increased until it reaches the maximum of the cycle length or, if a slab sensor is used, the slab temperature reaches the slab maximum setting. The Heat 2 relay is then cycled and its on time is increased as the load increases. When the heating load decreases, the on time of the Heat 2 relay is reduced until the Heat 2 relay is turned off completely. The thermostat then reduces the on time of the Heat 1 relay.

Note: When using a slab sensor, the Heat 2 relay may be on while the Heat 1 relay is off if the slab temperature has reached the slab maximum setting.

Air Sensor(s) Only Operation

When operating with only an air sensor, the on times for the Heat 1 and Heat 2 relays are calculated to satisfy the requirements of the air sensor.

Slab Sensor Only Operation

When operating with only a slab sensor, the on times for the Heat 1 and Heat 2 relays are calculated to satisfy the requirements of the slab sensor. The thermostat operates to maintain the slab at the minimum slab temperature setting.

Note: Operating with only a slab sensor can lead to either overheating or underheating of the space.

Air and Slab Sensor Operation

When operating with both air and slab sensors, the thermostat calculates an on time for the Heat 1 relay to satisfy the slab sensor's requirements and on times for the Heat 1 and Heat 2 relays to satisfy the air sensor's requirements. The thermostat operates the Heat 1 relay for the longer of these two on times.

While the minimum slab temperature is satisfied, the on times of the Heat 1 and Heat 2 relays are calculated to satisfy the air temperature requirements.

During heavy loads, the maximum slab temperature setting limits the on time of the Heat 1 relay. In this situation, the Heat 2 relay may be on while the Heat 1 relay is off.

Note: During light heating loads, overheating can occur due to the minimum slab temperature requirements.

Mode

Heat In the heat mode, the Heat 1 and Heat 2 relays are operated to satisfy the temperature requirement of the zone. **Off** In the Off mode, the Heat 1 and Heat 2 relays are not operated.

Note: If an air or slab sensor is active in the Off mode, a freeze protection is enabled that allows the relays to be operated to keep the zone above 35°F (2°C).

PD2 (Heat / Cool)

The Heat / Cool mode of operation is selected using the DIP switch located on the circuit board inside the thermostat.

Air Sensor(s) Only Operation

When operating with only an air sensor, the on times of the Heat 1 relay and the Cool relay are calculated to satisfy the requirements of the air sensor.

Slab Sensor Only Operation

When operating with only a slab sensor, the on time of the Heat 1 relay is calculated to satisfy the requirements of the slab sensor. The thermostat operates to maintain the slab at the minimum slab temperature setting.

Note: When operating with only a slab sensor, the Cool relay does not operate. Operating with only a slab sensor can lead to either overheating or underheating of the space.

Air and Slab Sensor Operation

When operating with both air and slab sensors, the thermostat calculates an on time for the Heat 1 relay to satisfy the slab sensor's requirements and an on time to satisfy the air sensor's requirements. The Heat 1 relay operates for the longer of these two on times. The thermostat also calculates an on time for the Cool relay to satisfy the air sensor's requirements. In this situation, heating and cooling can happen at the same time to prevent the space from overheating. This is most likely to occur when the slab is operating at the slab minimum temperature.

While the minimum slab temperature is satisfied, the Heat 1 relay on time is calculated to satisfy the air temperature setting. However, the maximum slab temperature setting limits the Heat 1 relay on time when the slab temperature becomes too warm. In this situation, under heating can occur in the space.

Mode

Auto In the Auto mode, the thermostat automatically switches between heating and cooling the space. However, the heating operation has priority over the cooling operation. In this mode, the minimum slab temperature is maintained even when the thermostat is cooling the air.

Heat In the Heat mode, the Heat 1 relay is operated to satisfy the heating temperature requirement of the zone and cooling is disabled.

Cool In the Cool mode, the Cool relay is operated to satisfy the cooling temperature requirement of the zone and heating is disabled. If a slab sensor is used, the slab minimum is ignored.

Off In the Off mode, the Heat 1 and Cool relays are not operated.

Note: If an air or slab sensor is active in the Off mode, a freeze protection is enabled that allows the Heat 1 relay to be operated to keep the zone above 35°F (2 °C) .

Heating / Cooling Interlock Time Interlock

In order to prevent frequent changes between heating and cooling, the thermostat has a Cooling Interlock setting. Once the Heat 1 relay has been off for a minimum of one heating cycle or the length of the Cooling Interlock, (whichever is longer) cooling is permitted.

Temperature Interlock

When in the Auto mode, the cooling temperature is limited to 3°F (1.5°C) above the heating temperature . If the cooling temperature is set below the heating temperature, the thermostat automatically adjusts the cooling setpoint. When operating in the Cool mode, there is no interlock between the heating and cooling temperature.

Installation

STEP ONE GETTING READY

Check the contents of this package. If any of the contents are missing or damaged, please contact your wholesaler or REHAU technical associate for assistance.

Type PD1 Includes: One Programmable Thermostat PD1, PD1 / PD2 Instructions

Type PD2 Includes: One Programmable Thermostat PD2, PD1 / PD2 Instructions

STEP TWO REMOVING THE FRONT COVER

Place a screwdriver or similar object into the small slot located in the top of the thermostat. Push the screwdriver against the plastic tab and pull the top of the front cover so that it pivots around the bottom edge of the base.

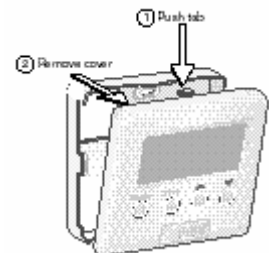

STEP THREE MOUNTING THE BASE

The thermostat should be installed on an interior wall of the desired zone approximately 5' (1.5m) above the floor. Do not mount the thermostat in a location that may be affected by localized heat sources or cold drafts. It may be necessary to install a draft barrier behind the thermostat to prevent air from blowing through the wiring hole and affecting the thermostat's built-in sensor.

Mount the base directly to the wall using two #6 1" screws. The screws are inserted through the mounting holes and must be securely fastened to the wall. If possible, at least one of the screws should enter a wall stud or similar surface. If the thermostat is to be mounted to a 2" x 4" electrical box, order an Adapter Plate 007. This plate mounts to the electrical box and the thermostat mounts to the plate. Ensure that the electrical box does not provide cold air to the thermostat.

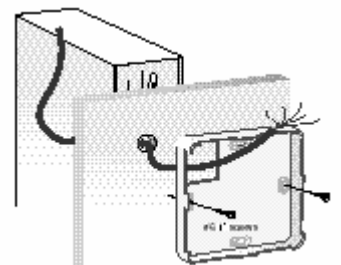

Note: If the thermostat is to be used for remote sensing (i.e. The built-in

air sensor is disabled and an indoor sensor is being used.) Mount the thermostat in the desired location in an appropriate manner.

STEP FOUR

ROUGH IN WIRING

- 18 AWG or similar wire is recommended for all 24 V (ac) wiring.
- All wires are to be stripped to ¼" (6mm) to ensure proper connection to the control.
- Run wires from the 24 V (ac) power to the thermostat. Use a clean power source to ensure proper operation.
- If an auxiliary sensor is used, install the sensor according to the appropriate Data Brochure and run two wires from the sensor to the thermostat.
- Run wires from the heating and / or cooling device to the thermostat.

STEP FIVE

WIRING THE THERMOSTAT (Refer to the examples on the following pages.)

24 V (ac) Power

Connect the 24 V (ac) power to the R and C terminals (1 and 2) of the thermostat. This connection provides power to the microprocessor and display of the thermostat.

Auxiliary Sensors (S1 and S2)

Either an indoor, slab, or remote sensor may be connected to the S1 input. Connect the two wires from the auxiliary sensor to the Com and S1 terminals (3 and 4).

Heat Relay (PD1 and PD2)

The Heat (1) terminals (5 and 6) are an isolated output. There is no power available on these terminals from the thermostat. These terminals are to be used as a switch for a 24 V (ac) circuit. This circuit can operate a low current 24 V (ac) device directly or an external relay to enable a line voltage or high current device.

Heat 2 / Cool (PD2)

The Heat 2 / Cool terminals (7 and 8) are an isolated output. There is no power available on these terminals from the thermostat. This circuit can operate a low current 24 V (ac) device directly or an external relay to enable a line voltage or high current device.

STEP SIX

INSTALLING THE FRONT COVER

Align the hinges on the bottom of the front cover with the bottom of the thermostat-mounting base. Pivot the front cover around the bottom hinges and push the top against the mounting base until it snaps firmly in place.

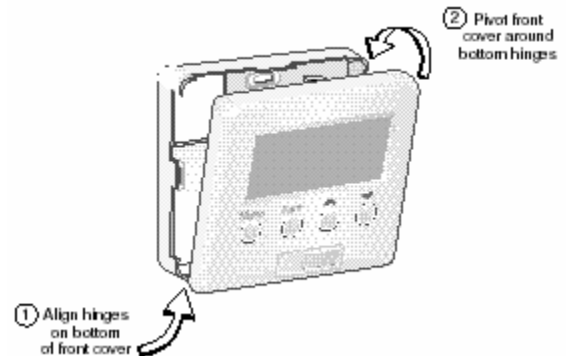

View Menu (1 of 1) – User access level

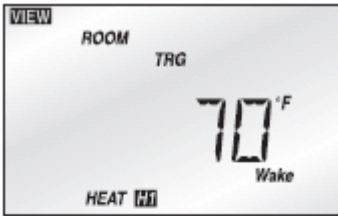

Room Target

The current desired air temperature for the space. This item is only available in the Installer access level. *(Must have an active air sensor.)*

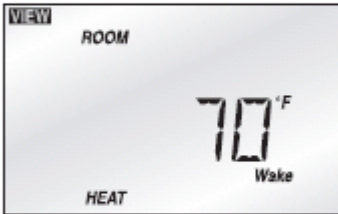

Room

The current air temperature for the space. If the optional sensor is not used for the floor/slab but for the room, this is the average temperature.



Outdoor

The current temperature at the outdoor sensor . *(Sens 2 must be set to Out.)* is the average of all active air sensors.)



Slab

The current slab temperature. *(Must have an active slab sensor.)*



Remote

The current temperature at the remote sensor. *(Sens 1 must be set to Rem.)*

Adjust Menu (1 of 6) – Installer access level

Notes:

- 1- DIP switch must be set to allow access.
- 2- Press the MENU button to access. Press \wedge or \vee to change
- 3- Depending on the **HEAT, COOL or AUTO** option selected, the sequence of illustrated below will differ.



Mode

Current mode of operation the thermostat.

OFF, HEAT (PD1)

OFF, COOL, AUTO, HEAT (PD2)



Room Heat (No Schedule)

Desired temperature for heating. (Must have an active air sensor and be set to either Heat or Auto.) 35 to 100°F (1.5 to 38.0°C)



Room Cool (No Schedule)

Desired temperature for cooling.

(Must have an active air sensor and be set to either Cool or Auto.)

35 to 100°F (1.5 to 38.0°C)



Slab Minimum (No Schedule) Minimum desired slab temperature.

(Must have an active air sensor and be set to either Heat or Auto).

OFF, 34 to 122°F (OFF, 1.0 to 50.0°C)



Room Heat Wake

Desired room temperature at wake-up.

(Must have an active air sensor and be set to either Heat or Auto).

35 to 100°F (1.5 to 38.0°C)

NOTE: wake, un-occupied, occupied and sleep times are inputted in the "schd" menu.

Adjust Menu (2 of 6)



Room Heat UnOcc

Desired temperature during un-occupied times.
(Must have an active air sensor and be set to either Heat or Auto)
35 to 100°F (1.5 to 38.0°C)



Room Heat Occ

Desired temperature for occupied times.
(Must have an active air sensor and be set to either Heat or Auto)
35 to 100°F (1.5 to 38.0°C)



Room Heat Sleep

Desired temperature for Sleep time.
(Must have an active air sensor and be set to either Heat or Auto)
35 to 100°F (1.5 to 38.0°C)



Room Cool Wake

Desired room temperature for cooling at wake time.
(Must have an active air sensor and be set to either Cool or Auto)
35 to 100°F (1.5 to 38.0°C)



Room Cool UnOcc

Desired temperature for cooling during UnOccupied times.
(Must have an active air sensor and be set to either Cool or Auto)
35 to 100°F (1.5 to 38.0°C)

Adjust Menu (3 of 6)



Room Cool Occ

Desired temperature for cooling during Occupied times.
(Must have an active air sensor and be set to either Cool or Auto)
35 to 100°F (1.5 to 38.0°C)



Room Cool Sleep

Desired temperature for cooling during Sleep time.
(Must have an active air sensor and be set to either Cool or Auto)
35 to 100°F (1.5 to 38.0°C)



Slab Minimum Wake

Minimum slab temperature at wake time.
(Must have an active slab sensor.)
OFF, 34 to 122°F (OFF, 1.0 to 50.0°C)



Slab Minimum UnOcc

Minimum slab temperature during UnOccupied time.
(Must have an active slab sensor.)
OFF, 34 to 122°F (OFF, 1.0 to 50.0°C)



Slab Minimum Occ

Minimum slab temperature during Occupied time.
(Must have an active slab sensor.)

Adjust Menu (4 of 6)



Slab Minimum Sleep

Minimum slab temperature during Sleep time.
(Must have an active slab sensor.)
OFF, 34 to 122°F (OFF, 1.0 to 50.0°C)



Slab Maximum

Maximum slab temperature. This item is only available in the installer access level. (Must have an active slab sensor.)
34 to 122°F, OFF (1.0 to 50.0°C, OFF)



Sensor 1

Selects the type of auxiliary sensor present in the Sen 1 input. This item is only available in the Installer access level.
OFF, Indr (thermostat averages in this case), SLAB, OUTside



Room Sensor

Selects whether the built-in sensor is functional or not. This item is only available in the Installer access level.
OFF, ON



Heating Cycle

Determines the number of cycles per hour for the heating equipment. This item is only available in the Installer access level. This adjustment would be to influence "short cycling" of the heating system. **Auto, 2 to 12**

Adjust Menu (5 of 6)



Cooling Cycle

Determines the number of cycles per hour for the cooling equipment. This item is only available in the Installer access level.
Auto, 2 to 12



Cooling Interlock

Selects the time delay between the heating and cooling relays. This item is only available in the Installer access level.
10 to 180 min.



Cooling Minimum On

Sets the minimum on time of the cooling contact. This is to prevent short cycling. This item is only available in the Installer access level.
0:30 to 5:00 min.



Cooling Minimum Off

Sets the minimum off time of the cooling contact. This is to prevent short cycling. This item is only available in the Installer access level.
0:30 to 10:00 min.



Early Start

Selects whether or not the Early Start (anticipation) feature is active. This item is only available in the Installer access level.
OFF, ON

Adjust Menu (6 of 6)



Lite

Sets the operation of the back lighting of the LCD. ON, Tmpy ON, OFF



Units

The units of temperature used to display the items.
F, C

Error Messages (1 of 2)



E01 The thermostat was unable to read a piece of information stored in its memory. The thermostat was required to load the factory settings. The thermostat will stop operation until all settings are checked. To clear this error, select the Installer access level and check all of the settings in the Adjust and Schedule menus.



E02 There are no active sensors selected on the thermostat. Either the internal sensor must be turned on or at least one auxiliary sensor must be set to either INDR or SLAB. After the fault is corrected, press any button to clear the error message.



Room Short

The thermostat's internal air sensor is short circuit. This cannot be repaired in the field. The thermostat should be replaced or returned for repair.



Room Open

The thermostat's internal air sensor is open circuit. This cannot be repaired in the field. Either turn off the internal sensor and use an auxiliary sensor set to INDR or replace the thermostat. After the fault is corrected, press any button to clear the error message.

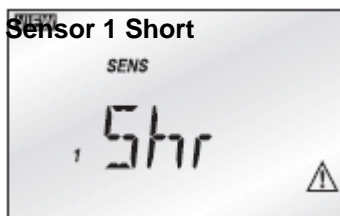

Sensor 1 Short

The auxiliary sensor connected to the Sens 1 terminal is short circuit. Locate and repair the problem as described in the appropriate sensor brochure. After the fault is corrected, press any button to clear the error message.

Error Messages (2 of 2)



Sensor 1 Open The auxiliary sensor connected to the Sens 1 terminal is open circuit. Locate and repair the problem as described in the appropriate sensor brochure. After the fault is corrected, press any button to clear the error message.

Wiring Examples (1 of 3)

WIRING 24 V (AC) POWER AND AUXILIARY SENSORS

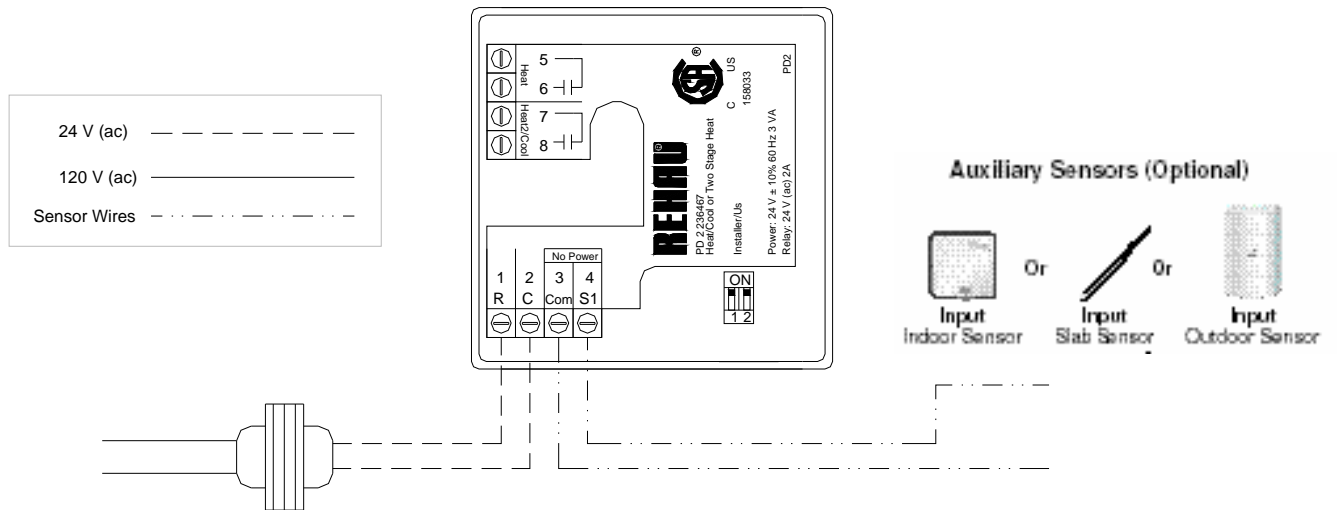

WIRING THE PD1

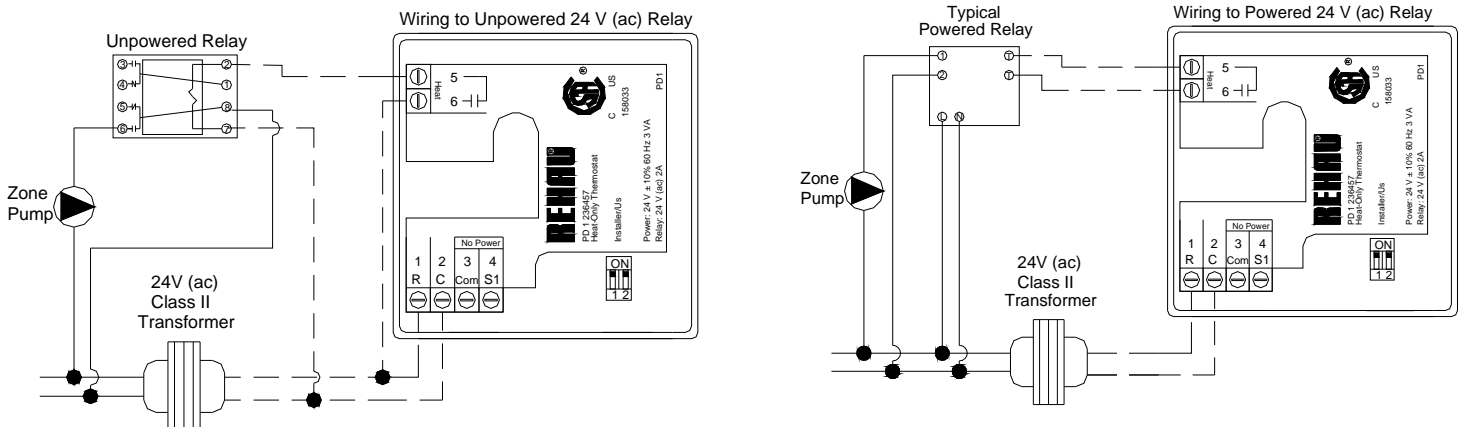
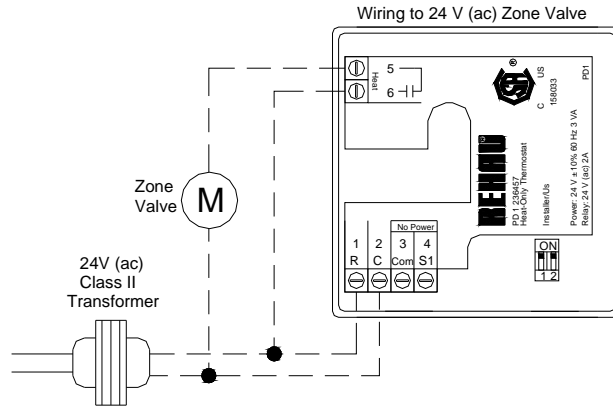

Wiring Examples (2 of 3)

WIRING THE PD2

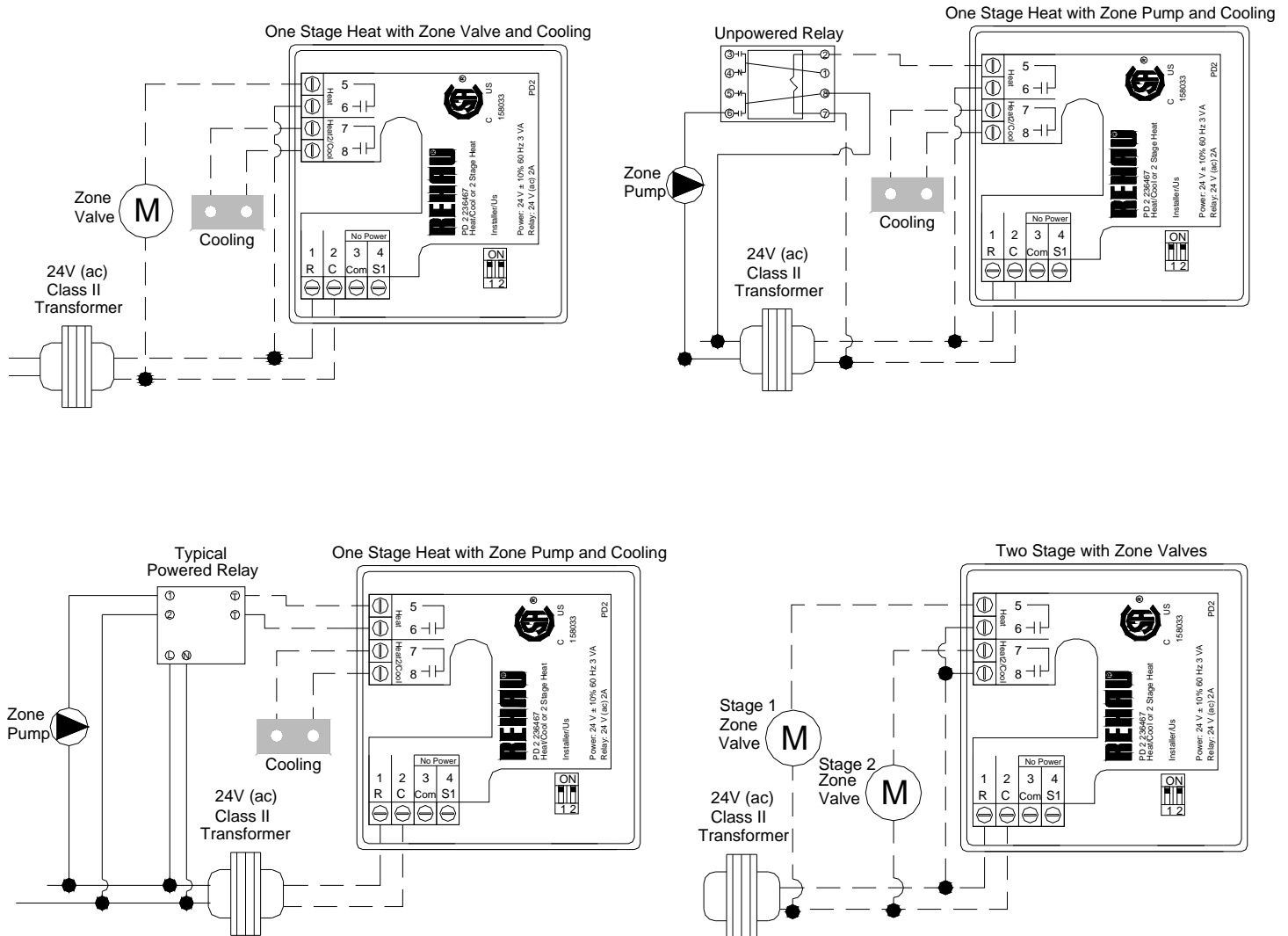

Wiring Examples (3 of 3)

