

Munchkin Boilers

Venting and Condensate Management

The total combined length of pipe (intake piping plus exhaust piping added together) including elbow allowances intake and exhaust (each elbow = 5' of pipe) should **not exceed 85'** and **not be less than a combined length of 6' plus two 90 degree elbows.** Schedule 40 solid core minimum.

Friction Loss 3" Pipe Equivalent in Piping and Fittings or Piping Equivalent Feet

90 degree elbow = 5 45 degree elbow = 3
 Coupling = 0 Air inlet tee = 0
 Plastic Pipe = 1 Concentric vent kit = 3

Longer Vent Runs Transitioning to 4" Venting



Transitioning from 2" to 3" or 3" to 4" should be done in the vertical position to avoid condensation blockage. If done in the horizontal position check to make sure condensation blockage will not occur.

4" 90 degree elbow = 3 Equivalent Feet
 4" 45 degree elbow = 1 Equivalent Feet
Maximum distance is 125 feet

Exhaust venting



Foam Core Pipe is not to be used in connecting the exhaust pipe.

- ✓ The Munchkin is a direct vent appliance.
- ✓ The Munchkin Venting is rated at Zero Clearance to combustibles.
- ✓ Vent lengths outside of the recommended range may not stop system operation; however, the unit will operate at a reduced capacity.

Inlet Air Vent

- Use the same material as used for exhaust in either 2", 3" or 4" Plastic Pipe.
- Cellular Foam Core Pipe may be used for the inlet only.

Condensate Management

The condensate must not be exposed to freezing temperatures, or any other type of blockage.

Plastic tubing should be the only material used for the condensate line.

A vent tee is required, and an increase to 1" tubing may be necessary.

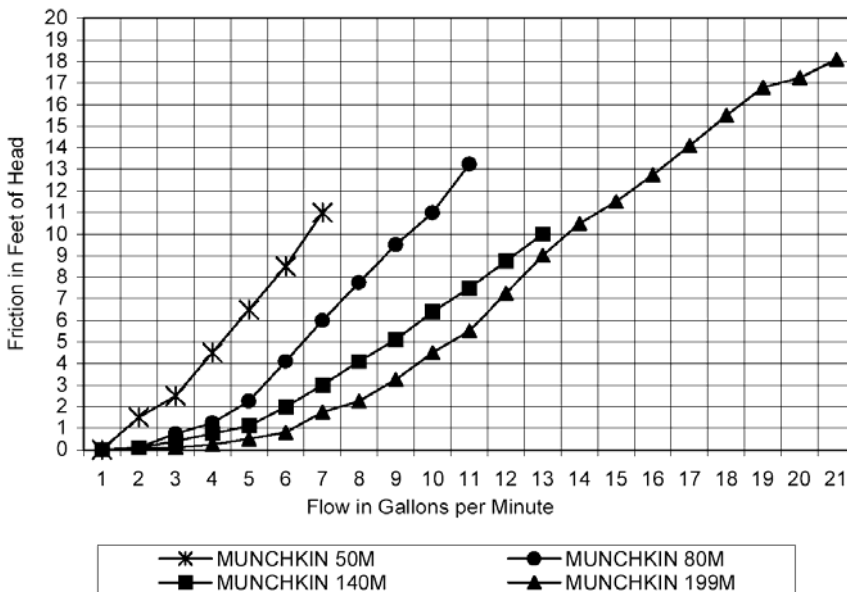

Primary Loop Flow Rates

The reference chart is found inside your installation manual shipped with your boiler.

A Strainer is recommended on all Munchkin boiler installations.

BOILER	TACO P/N	GRUNDFOS P/N
50M/80M	007	UPS 15-58FC SPD-2
140M	0010	UP 26-64 F
199M	0011	UP 26-96 F

RECOMMENDED CIRCULATORS ARE BASED ON 1 GPM PER 10,000 BTU/HR

Set Up and Valve Identification

⚠ WARNING

Failure to follow all precautions could result in fire, explosion or death!

IF THE THROTTLE ADJUSTMENT SCREW IS ADJUSTED, A "COMBUSTION ANALYZER" MUST BE USED TO ENSURE SAFE AND PROPER OPERATION.

TURNING THE SCREW **CLOCKWISE DECREASES** YOUR GAS FLOW WHICH WILL LOWER THE CO/CO₂% LEVELS.

TURNING THE SCREW **COUNTER CLOCKWISE INCREASES** YOUR GAS FLOW WHICH WILL RAISE THE CO/CO₂% LEVELS

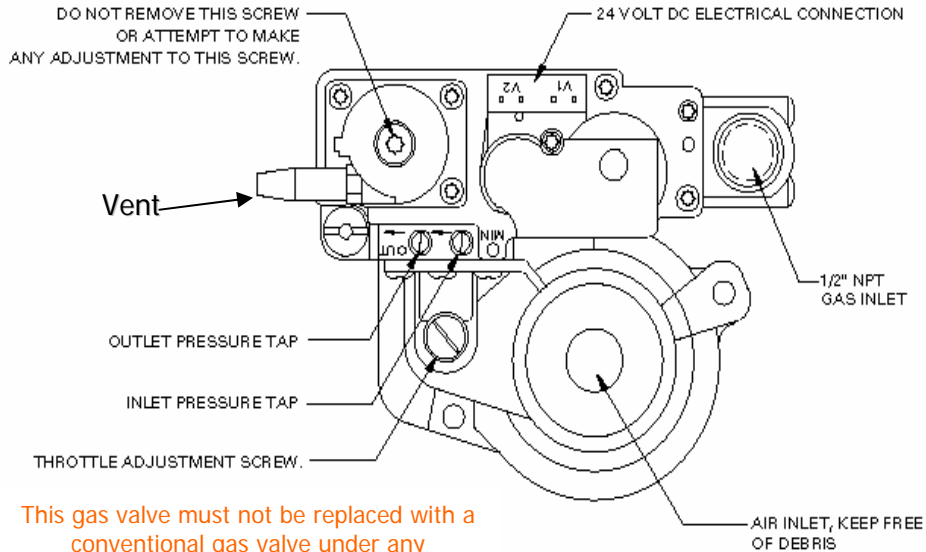

This gas valve must not be replaced with a conventional gas valve under any circumstances. As an additional safety feature, this gas valve has a flanged connection to the Venturi and blower.

COMBUSTION SETTINGS					
HIGH FIRING RATES and LOW FIRING RATES ON ALL MODELS					
	Natural Gas		Propane LP		
	low	high	low	high	
Carbon Monoxide CO ppm	0-20 ppm	80 - 135 ppm	0-20 ppm	80 -150 ppm	
Carbon Dioxide CO ₂	8-1/2 %- 9-1/2%	8-1/2 %- 9-1/2 %	9-1/2 %- 10-1/2 %	9-1/2 %- 10-1/2 %	

Questions
Call TSI Hydronics or Tech Service department at:

Green Bay Office

(920.499.1300) Jamie x 221
(920.499.1301) Dave x 220
(920.499.1302) Corey x 246

Madison Office

(608.271.5959) Dan x334
(608.271.5959) Jeff x317
(608.271.5959) Robert x303

Wiring

There are two ground points in the electrical compartment that must be connected to the building ground system.

Connect the building ground to the green ground screw and the green ground wire inside electrical box provided.

The Incoming Power Supply is connected to the Black (Hot) and the White (Neutral).

If the polarity is reversed, the Munchkin control may not sense a flame and lock out the system. The Orange and Brown wire are provided to the supply of 120 volts to the Central Heating Circulator.

Connect the Orange (Hot) and the Brown (Neutral) directly to the Central Heating Circulator.

Connect the gray wires to your heating thermostat (TT) connection.

⚠ DANGER!

IT IS EXTREMELY IMPORTANT THAT THIS UNIT BE PROPERLY GROUNDED!

Connect the gray wires to your heating thermostat (TT) connection.

Your thermostat heat anticipator setting is .056 amp.

Munchkin Tips

F00 –

- Board is sensitive to stray voltage on TT wires. Disconnect the two gray TT wires and connect them together. Reset. The unit should run. If so, the problem resides in the polarity of the end switch wires or in the end switch.

Nc on display –

- Check for proper polarity to the power leads. Run separate ground wire to good known earth ground (not to electrical panel). Most often this is indicative of a faulty neutral connection.

Ignition problems –

- Block the air intake $\frac{3}{4}$ of the way and re-start the unit. If the unit fires, adjustments of the throttle screw may be necessary. Reference the installation manual. Adjust to 105 ppm CO at the exhaust breach in high fire.
- Remove ignitor (11 O'clock position on face plate) Check the Gap; it should be $\frac{1}{4}$ inch.
- The ignitor should be directed toward the burner. If it is not, please contact TSI.

F10 Failing While Running –

- Check that the condensate is draining freely from the boiler.
- Make certain that the unit is properly grounded, and that no stray current is running through the neutral or ground wires.
- Remove and inspect and/or clean the flame rod. Check the reading with the unit running – Press and hold S4 button. D1 will alternate with a value. Press S4 until you get to D7. D7 is the flame rod reading. On high fire, the reading should be as follows: **80M- 4.1 140M- 4.2 199M- 4.3**. Check the flame sensor. If your current reading is in the low 3 range, some adjustment should be made to the flame sensor. Slightly increase the bends in the ignitor so it is located closer to the burner. It should be **8mm** off the burner surface.
- Check CO levels at the exhaust breach. On high fire they should be 105-110 ppm. See manual for adjustment procedure.
- If there is a concentric vent kit installed – check that it has been properly assembled and that all joints have been glued.
 - **Exhaust gas re-circulation will cause the unit to fire then fail almost immediately or fail if the wind causes re-circulation at the termination.**

F10 Failing While Running – continued –

- If this does not resolve the issue, replace the flame sensor.

Alarm Contact –

There is an alarm contact available within the 925 control that will provide 110 volts to a remote output whenever a fault is present. This output is accessible through one of the unused terminals on the 925 control. Munchkin will soon be offering an optional wiring package to utilize this relay.

Freeze Protection –

The Munchkin has built in freeze protection. When the return thermistor senses a temperature less than 45 degrees, the central heating circulator will be energized. If the temperature continues to drop, the burner will engage at 38 degrees, and continue to run until the return sensor reaches 50 degrees.

Vision 1–

- Two different temperatures from one control.
- Vision 1 is available to individuals who have successfully completed the required training.
- If the boiler is not used for heating domestic hot water; the high temperature option can be used to supply baseboard or air handling equipment using the blue aquastat wires as thermostat wires, the purple and pink wires are the circulator wires.
- *The water temperature supplied to this zone is fixed at 194 degrees.*
- The priority timing is variable from 1 to 60 minutes.

Unit will not operate –

- Is the supply power applied from a commercial source (local utility)? The system is not designed to run from a generator.
- Did you install the vision 1 package? Sometimes a misalignment can occur when reinstalling the straight pin connector. Check a second time before Applying power!
- Is there a status code present? Correct as directed in the installation and service manual.

Record all changes

- Record all changes in temperature settings and CO on completion of the job.
- Plot your New Central Heating Curve on fig. 4-2 in the Vision Package

Things to Remember...

When attempting to change the temperature settings:

- To change the temperature you must make certain there are no active calls for heat. (When connected, an indirect sensor is a call for heat)
- The Munchkin controller will not memorize a program setting while in a heating cycle.

Vision 1

- You can not exceed the set point of function 9 (supply temperature at the minimum outside temperature).
- The factory setting is 180 degrees.
- By altering the Central Heating Temperature you alter the heating curve.

In addition to changing the temperature you are also allowed to change three more settings.

- Munchkin differential**
- Indirect setting (Vision System Only)**
- Celsius to Fahrenheit measurement**

The outdoor sensor

- Always mount out of direct sunlight and on the coldest wall (north).
- Mount the outdoor sensor above the anticipated snow level.

Beginning the cycle

- The Munchkin has a 6 step function based on rated output. The boiler starts in low and modulates to meet demand. This is adjusted at one minute intervals.

Model	Supply/Return Connection	Gas Connection Size	Vent Dia.
T50	1¼" NPT	¾"	2"
T50	1¼" NPT	¾"	2"
80M	1¼" NPT	¾"	3"
140M	1¼" NPT	¾"	3"
199M	1¼" NPT	¾"	3"
399M	2" NPT	1¼"	4"

All gas lines need a minimum of 10 feet.

This line length must be maintained after a regulator before connecting to the factory supplied gas connection.

Gas piping should never be reduced below ¾ of an inch black iron pipe.

Check internal gas cock and connections for leaks before firing system.

Model	Input Modulation	AFUE Efficiency	Shipping Weight
T50 *	10,000 - 50,000	92%	58 Lbs.
T80 *	15,000 - 80,000	92%	58 Lbs.
80M	22,000 - 80,000	92%	75 Lbs.
140M	44,00 - 140,000	92%	101 Lbs.
199M	66,00 - 199,000	92%	111 Lbs.
399M	100,000 - 399,000	93%	252 Lbs

*** Shipped for Natural gas.**

All units are field convertible for LP gas by turning IN (clockwise) the air adjustment screw by 3 complete turns.