

Tech Tips II Temperature Systems Inc.

Madison -- Green Bay -- Jan 05

Tech Tips II: Troubleshooting EconoMi\$er IV

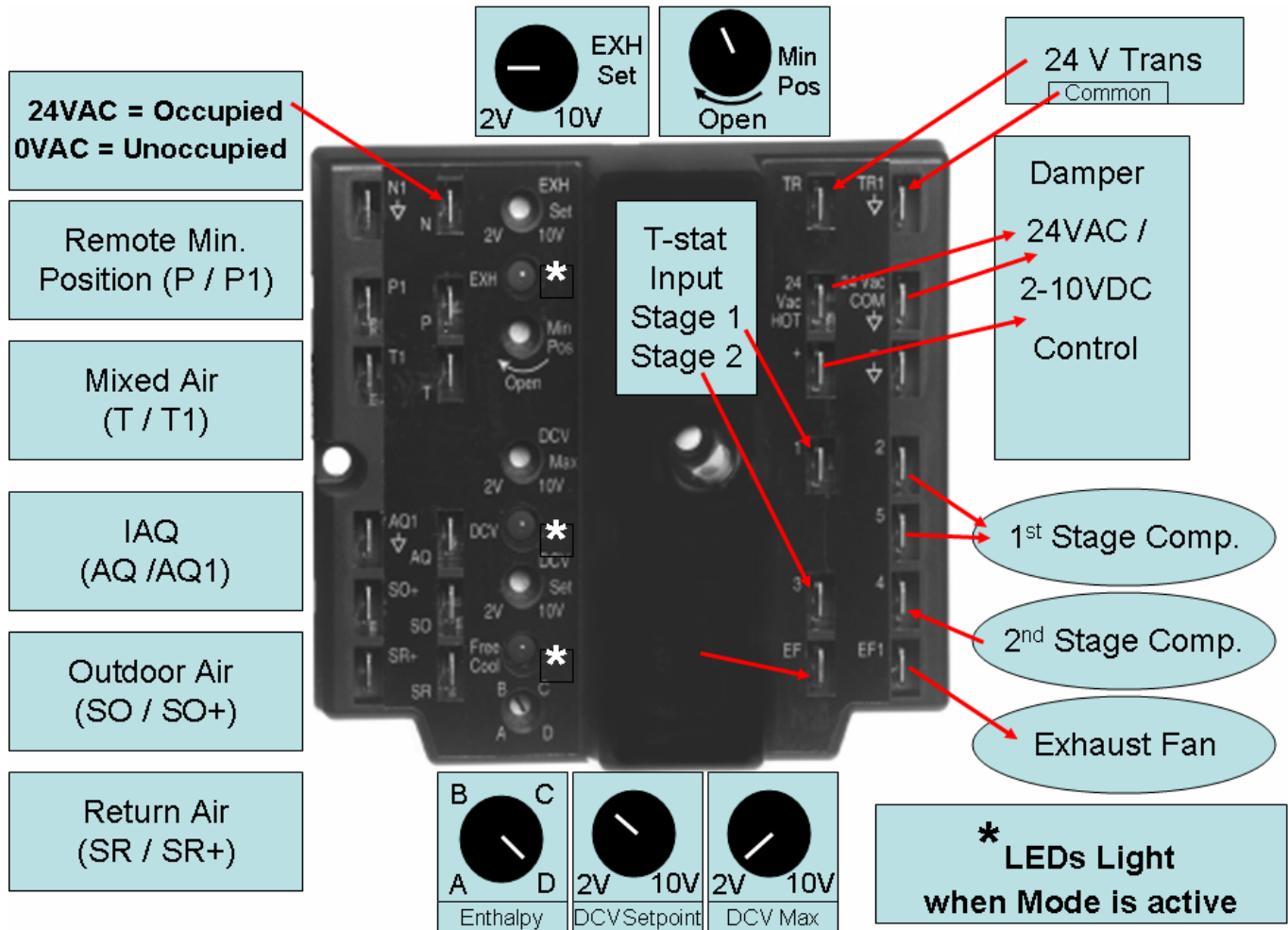

EconoMi\$er IV Troubleshooting

See Diagram above for EconoMi\$er IV layout.

See Table 1 for input output logic.

Note: Damper movement from full open to full closed (or vice versa) takes 2.5 minutes.

ECONOMI\$ER IV PREPARATION

This procedure is used to prepare the EconoMi\$er IV for troubleshooting. No troubleshooting or testing is done by performing the following procedure.

NOTE: This procedure requires a 9-v battery, 1.2 kilo-ohm resistor, and a 5.6 kilo-ohm resistor which are not supplied with the EconoMi\$er IV

1. Disconnect power at TR and TR1. All LEDs should be off. Exhaust fan contacts should be open.
2. Disconnect device at P and P1.
3. Jumper P to P1.
4. Disconnect wires at T and T1. Place 5.6 kilo-ohm resistor across T and T1.

Tech Tips II: Troubleshooting EconoMi\$er IV

5. Jumper TR to 1.
6. Jumper TR to N.
7. If connected, remove sensor from terminals SO and +. Connect 1.2 kilo-ohm 4074EJM checkout resistor across terminals SO and +.
8. Put 620-ohm resistor across terminals SR and +.
9. Set minimum position, DCV set point, and exhaust potentiometers fully CCW (counterclockwise).
10. Set DCV maximum position potentiometer fully CW (clockwise).
11. Set enthalpy potentiometer to D.
12. Apply power (24 vac) to terminals TR and TR1.

DIFFERENTIAL ENTHALPY

To check differential enthalpy:

1. Make sure EconoMi\$er IV preparation procedure has been performed.
2. Place 620-ohm resistor across SO and +.
3. Place 1.2 kilo-ohm resistor across SR and +. The Free Cool LED should be lit.
4. Remove 620-ohm resistor across SO and +. The Free Cool LED should turn off.
5. Return EconoMi\$er IV settings and wiring to normal after completing troubleshooting.

SINGLE ENTHALPY

To check single enthalpy:

1. Make sure EconoMi\$er IV preparation procedure has been performed.
2. Set the enthalpy potentiometer to A (fully CCW). The Free Cool LED should be lit.
3. Set the enthalpy potentiometer to D (fully CW). The Free Cool LED should turn off.
4. Return EconoMi\$er IV settings and wiring to normal after completing troubleshooting.

DCV (Demand Controlled Ventilation) AND POWER EXHAUST

To check DCV and Power Exhaust:

1. Make sure EconoMi\$er IV preparation procedure has been performed.
2. Ensure terminals AQ and AQ1 are open. The LED for both DCV and Exhaust should be off. The actuator should be fully closed. **IMPORTANT:** Be sure to record the positions of all potentiometers before starting troubleshooting.
3. Connect a 9-v battery to AQ (positive node) and AQ1 (negative node). The LED for both DCV and Exhaust should turn on. The actuator should drive to between 90 and 95% open.
4. Turn the Exhaust potentiometer CW until the Exhaust LED turns off. The LED should turn off when the potentiometer is approximately 90%. The actuator should remain in position.
5. Turn the DCV set point potentiometer CW until the DCV LED turns off. The DCV LED should turn off when the potentiometer is approximately 9v. The actuator should drive fully closed.
6. Turn the DCV and Exhaust potentiometers CCW until the Exhaust LED turns on. The exhaust contacts will close 30 to 120 seconds after the Exhaust LED turns on.
7. Return EconoMi\$er IV settings and wiring to normal after completing troubleshooting.

DCV MINIMUM AND MAXIMUM POSITION

To check the DCV minimum and maximum position:

1. Make sure EconoMi\$er IV preparation procedure has been performed.
2. Connect a 9-v battery to AQ (positive node) and AQ1 (negative node). The DCV LED should turn on. The actuator should drive to between 90 and 95% open.
3. Turn the DCV Maximum Position potentiometer to midpoint. The actuator should drive to between 20 and 80% open.

Tech Tips II: Troubleshooting EconoMi\$er IV

4. Turn the DCV Maximum Position potentiometer to fully CCW. The actuator should drive fully closed.
5. Turn the Minimum Position potentiometer to midpoint. The actuator should drive to between 20 and 80% open.
6. Turn the Minimum Position Potentiometer fully CW. The actuator should drive fully open.
7. Remove the jumper from after completing troubleshooting.

6. Remove 1.2 kilo-ohm checkout resistor from terminals SO and +. If used, reconnect sensor from terminals SO and +.
7. Remove jumper from TR to N.
8. Remove jumper from TR to 1.
9. Remove 5.6 kilo-ohm resistor from T and T1. Reconnect wires at T and T1.
10. Remove jumper from P to P1. Reconnect device at P and P1.
11. Apply power (24vac) to terminals TR and TR1.

SUPPLY-AIR INPUT

To check supply-air input:

1. Make sure EconoMi\$er IV preparation procedure has been performed.
2. Set the Enthalpy potentiometer to A. The Free Cool LED turns on. The actuator should drive to between 20 and 80% open.
3. Remove the 5.6 kilo-ohm resistor and jumper T to T1. The actuator should drive fully open.
4. Remove the jumper across T and T1. The actuator should drive fully closed.
5. Return EconoMi\$er IV settings and wiring to normal after completing troubleshooting.

ECONOMI\$ER IV TROUBLESHOOTING COMPLETION

This procedure is used to return the EconoMi\$er IV to operation.

No troubleshooting or testing is done by performing the following procedure.

1. Disconnect power at TR and TR1.
2. Set enthalpy potentiometer to previous setting.
3. Set DCV maximum position potentiometer to previous setting.
4. Set minimum position, DCV set point, and exhaust potentiometers to previous settings.
5. Remove 620-ohm resistor from terminals SR and +.

Questions

Call TSI Tech Service department at:

Green Bay Office 920.499.1300 800.776.2014	Madison Office 608.271.7500 800.366.0930
Jamie ext. 221 Dave ext. 220	Dan ext. 334 Jeff ext. 317

Accessories:

- 4074EJM Bag Assembly. Consists of: Checkout jumper, 620 ohm, 1.2K ohm, 5.6K ohm, and 6.8K ohm checkout resistors.
- C7046A Discharge Air Temperature Sensor.
- C7150B Mixed Air Temperature Sensor.
- C7232A,B Carbon Dioxide Sensors.
- C7400 Solid State Enthalpy Sensor.
- C7650 Dry Bulb Temperature Sensor.
- S963B1128 Remote Potentiometer to provide remote control of damper minimum position.
- ST6008 Energy Management Timer for occupied/unoccupied control.

Tech Tips II: Troubleshooting EconoMi\$er IV

Table 1— EconoMi\$er IV Input/Output Logic

Inputs					Outputs			
Demand Control Ventilation (DCV)	Enthalpy*		Y1	Y2	Compressor	N Terminal †		
	Outdoor	Return			Stage 1	Stage 2	Occupied	Unoccupied
Below set (DCV LED Off)	High (Free Cooling LED Off)	Low	On	On	On	On	Minimum position	Closed
			On	Off	On	Off		
			Off	Off	Off	Off		
	Low (Free Cooling LED On)	High	On	On	On	Off	Modulating** (Between Min.Position and Full-open)	Modulating** (between Closed and Full-open)
On			Off	Off	Off			
Above Set (DCV LED On)	High (Free Cooling LED Off)	Low	On	On	On	On	Modulating †† (Between Min.Position and DCV Maximum)	Modulating ††† (between Closed and DCV Maximum)
			On	Off	On	Off		
			Off	Off	Off	Off		
	Low (Free Cooling LED On)	High	On	On	On	Off	Modulating***	Modulating †††
			On	Off	Off	Off		
			Off	Off	Off	Off		
*For single enthalpy control, the module compares outdoor enthalpy to the ABCD set point.					***Modulation is based on the greater of DCV and supply air sensor signals, between minimum position and either maximum position (DCV) or fully open (supply air signal).			
†Power at N terminal determines Occupied/Unoccupied setting: 24 vac (Occupied), no power (Unoccupied).					†††Modulation is based on the greater of DCV and supply air sensor signals, between closed and either maximum position (DCV) or fully open (supply air signal).			
**Modulation is based on the supply air sensor signal.					††Modulation is based on the DCV signal.			

Damper movement from full open to full closed (or vice versa) takes 2.5 minutes.